

## Solare II Integrated LED Solar Lighting



### Application

Car park, rural area, urban & residential street, security lighting, park & city area, bike & pedestrian path

### Luminaire Characteristic

Housing : Aluminium Alloy  
 Finishing : Grey  
 Solar panel : Monocrystalline  
 Light distribution : Type II, Type III, Type IV  
 Ingress Protection (IP) : IP65  
 Colour rendering (CRI) :  $\geq 70$   
 Colour temperature (CCT) : 3000K ~ 6000K

*Other CCT & CRI available upon request*

Weight : 15 kg ~ 86kg  
 Charging time :  $\leq 4.5$  hours  
 Discharge time :  $> 12$  hours  
 Recommended installation height : 2m to 12m

### Optional

Remote Control System & Smart Intelligent System available upon request

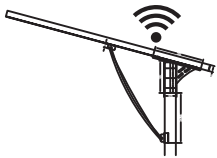

Energy saving with remote control system

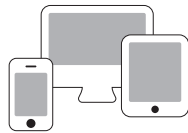

Network for smart intelligent system



Timer



Motion Sensor

## SOLARE II

### General Information

Autonomy days : 1 days  
 Working mode : 4hr - 100%, 2hr - 60%, 6hr - 40%  
 DoD : 80%

Code	LED Power	LEDs	Battery	Solar PV	Housing Dimension (axbxc)	Spigot Bracket Type	d	e	Weight
S2B02030	20W	42 LEDs	190Wh	60W	1040*360*50mm	Type I	60 - 100mm	120 - 550mm	15kg
S2B04030	40W	42 LEDs	380Wh	80W	1120*430*50mm	Type I	60 - 100mm	120 - 550mm	18kg
S2B06030	60W	84 LEDs	570Wh	100W	1440*430*50mm	Type II	92mm	260mm	21kg
S2B08030	80W	84 LEDs	760Wh	130W	1310*530*50mm	Type II	92mm	260mm	24kg
S2B10030	100W	84 LEDs	950Wh	160W	1350*695*95mm	Type II	92mm	260mm	32kg
S2B12030	120W	126 LEDs	1140Wh	200W	1500*695*95mm	Type II	92mm	260mm	36kg
S2B15030	150W	126 LEDs	1425Wh	240W	1620*795*95mm	Type II	92mm	260mm	43kg

\* The above ordering code is base on CCT~3000K

## SOLARE II - ADVANCE

### General Information

Autonomy days	: 2 days
Working mode	: 4hr - 100%, 2hr - 60%, 6hr - 40%
DoD	: 80%

Code	LED Power	LEDs	Battery	Solar PV	Housing Dimension (axbxc)	Spigot Bracket Type	d	e	Weight
S2A04030	40W	42 LEDs	760Wh	70W	1080*430*50mm	Type II	92mm	260mm	22kg
S2A06030	60W	84 LEDs	1140Wh	110W	1205*565*95mm	Type II	92mm	260mm	30kg
S2A08030	80W	84 LEDs	1520Wh	140W	1350*605*95mm	Type II	92mm	260mm	37kg
S2A10030	100W	84 LEDs	1900Wh	170W	1350*695*95mm	Type II	92mm	260mm	41kg
S2A12030	120W	126 LEDs	2280Wh	210W	1445*795*95mm	Type II	92mm	260mm	46kg
S2A15030	150W	126 LEDs	2850Wh	255W	1630*795*95mm	Type II	106mm	260mm	54kg

\* The above ordering code is base on CCT~3000K

## SOLARE II - PROFESSIONAL

### General Information

Autonomy days	: 3 days
Working mode	: 12hr - 100%
DoD	: 90%

Code	LED Power	LEDs	Battery	Solar PV	Housing Dimension (axbxc)	Spigot Bracket Type	d	e	Weight
S2P04030	40W	42 LEDs	1600Wh	170W	1350*695*95mm	Type II	92mm	260mm	38kg
S2P06030	60W	84 LEDs	2400Wh	255W	1630*795*95mm	Type II	106mm	260mm	50kg
S2P08030	80W	84 LEDs	3200Wh	255W	1630*795*95mm	Type II	106mm	260mm	56kg
S2P10030	100W	84 LEDs	4000Wh	400W	1765*1120*95mm	Type II	106mm	260mm	71kg
S2P12030	120W	126 LEDs	4800Wh	400W	1765*1120*95mm	Type II	106mm	260mm	77kg
S2P15030	150W	126 LEDs	6000Wh	400W	1765*1120*95mm	Type II	106mm	260mm	86kg

\* The above ordering code is base on CCT~3000K

Solare II - Type I

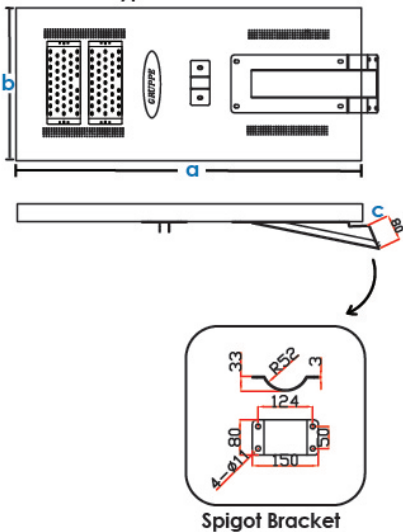

Solare II - Type II

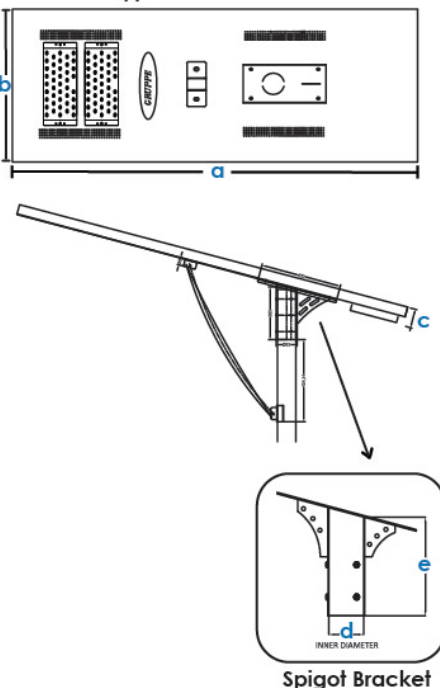

Solare II - Professional Type with Timer

